

CLIMATE

EMERALD TURBOVAP R-410A EVAPORATING UNITS

Based on the innovative engineering advancements of the award-winning Dometic Turbo self-contained air conditioning system, the Dometic Emerald TurboVap provides rapid removal of condensate water, has an enclosed blower motor, improved noise reduction, and an easily rotated blower. It offers improved installation ease and flexibility.

RUST-FREE DRAIN PAN
RAPID WATER REMOVAL

ROTATING BLOWER
UP TO 270° WITH 1 SCREW

QUIET OPERATION
MINIMAL VIBRATION



115V/50 OR 60Hz
230V/50 OR 60Hz



4,000 - 16,000 BTU

Mobile living made easy.

 **DOMETIC**

REDUCED SIZE, LESS NOISE, MORE COMFORT!



The Dometic Emerald TurboVap (TVE) direct expansion (DX) split-gas evaporator is based on the innovative engineering advancements of the award-winning Dometic Turbo self-contained air conditioning system. TVE units work with Dometic Emerald R-410A condensing units.

BENEFITS OF THE EMERALD TURBOVAP CONDENSING UNIT

- Rust-free composite drain pan has anti-splash, "positive flow" drain channels for no spills and rapid removal of condensate
- Designed to be used with Emerald Series R-410A condensers
- Vibration-isolation mounts reduce noise and vibration
- Single adjustment screw for 270 ° of blower rotation
- Powerful, efficient performance
- Compact design saves space

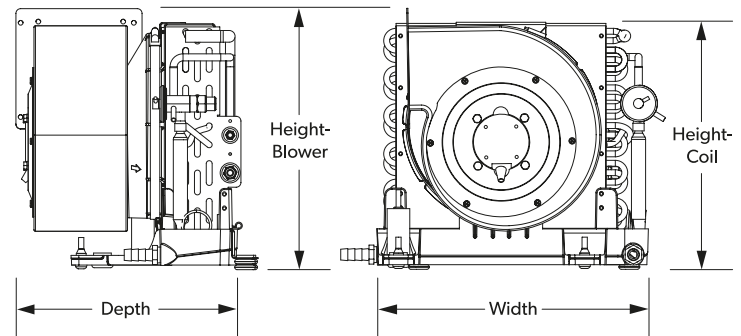

Model ¹	TVE4		TVE6		TVE8		TVE10		TVE12		TVE16	
Capacity (BTU/h)	4000		6000		8000		10000		12000		16000	
Voltage @ 50/60Hz 1-Ph (V)	115	230	115	230	115	230	115	230	115	230	115	230
Full Load Amps (FLA) Cool (A)	0.82	0.41	0.82	0.41	1.56	0.83	1.14	0.61	1.14	0.61	1.61	0.78
Max. Circuit Breaker (A)	5		5		5		5		5		5	
Min. Circuit Ampacity (A)	2	1	2	1	2	2	1	2	1	3	1	
Height-Coil (in/mm) ²	10.8/275		10.8/275		10.8/275		12.6/321		12.6/321		13/331	
Height-Blower (in/mm) ²	10.8/275		10.8/275		11.4/290		12.6/321		12.6/321		13.6/346	
Width (in/mm) ²	12.3/313		12.3/313		12.3/313		14.3/364		14.3/364		14.3/364	
Depth (in/mm) ²	9.5/242		9.5/242		9.4/239		10.4/265		10.4/265		11.6/295	
Min. Supply Duct Size (in/mm)	4/102		4/102		5/127		6/153		6/153		7/178	
Min. Supply Air Grille Size (sq in/sq cm)	32/207		32/207		48/310		60/388		70/452		81/523	
Min. Return Air Grille Size (sq in/sq cm)	64/413		64/413		80/517		110/710		130/839		160/1033	
Net Weight (lbs/kg) ³	10.5/4.8	11.25/5.2	12/5.5	12.25/5.6	14/6.4		17.5/8	17.5/8	17.75/8.1	20.5/9.3	21/9.6	
Gross Weight (lbs/kg) ³	18.5/8.4	18/8.2	19/8.7	20.25/9.2	22/10		25.5/11.6	25/11.4	25.5/11.6	24.75/11.3	28/12.8	28.5/13

¹ Add '115V' or '230V' to the model number for 115V and 230V units, respectively.

² All dimensions ± 0.30 in/8 mm.

³ All weights ± 10%.